



For Earth, For Life
Kubota

SVL

KUBOTA COMPACT TRACK LOADER SVL65-2

Easy operation, quick maneuverability, and exceptional cab comfort will make short work of a wide range of jobs.

A new CTL with the performance, operability, and comfort you need to take on and finish the job.

■ Exceptional Performance

Power to spare

A reliable 68HP Kubota engine brings plenty of power to any excavating or loading job, letting you work faster and with greater efficiency.

Wide working range

With the same vertical lift arm structure as Kubota's top of the line SVL's, the SVL65-2 boasts excellent lifting capacity, a long reach, and a high hinge pin.

Engine (gross HP)	68.3 HP
ROC (35% / 50%)	2100 lbs./3000 lbs.
Breakout force	4614 lbs.
Bucket Lift arm	4266 lbs.
Traction force	8408 lbs.
Reach	34.9 in.
Hinge pin height	118.5 in.

Self-leveling

The standard self-leveling during lifting feature, keeps the bucket or forks level without the need to manually adjust the angle. This function may be simply turned on and off with the flip of a switch.

High-flow hydraulics (option)

Get up to 27.0 gal/m AUX flow rate for greater attachment work efficiency.

14-pin coupler (option)

The 14-pin electrical coupler, and multifunction control grip switches allow for a multitude electrical functions to operate most attachments. 14-pin coupler comes standard with high-flow hydraulics.

■ Exceptional Comfort

Comfortable cab

Work in all day comfort in a cab that is equivalent in size to larger machines. A wide opening allows for easy entry and exit.

Easy-open sliding front door*

The sliding front door can be opened regardless of the position of the bucket or loader arms. Full machine operation is possible with the door open if desired.

■ Excellent operability

Kubota control valve system

The SVL 65-2 has an innovative hydraulic system developed exclusively by Kubota that enhances simultaneous operations, dramatically increasing the productivity of the bucket, and any AUX hydraulic attachment.



Note: Photos are SVL75-2 or SVL95-2S.

Multi-function grip (included with high-flow hydraulics option)

Multi-function levers provide fingertip control of all major vehicle and attachment operations, letting you keep both hands on the levers at all times.

Left Control Lever

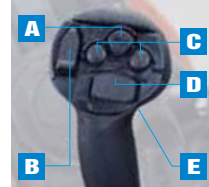

- A. Horn
- B. -Not used-
- C. AUX1
- D. AUX3
- E. Travel Speed

Right Control Lever



- F. Proportional AUX Switch
- G. AUX Hold Switch
- H. AUX2
- I. AUX Mode Change
- J. Float Switch

Excellent 360° visibility

All-round visibility lets you work safely and confidently. Even the bucket edge can be seen while sitting.

* The polycarbonate door is available as an optional kit and is recommended for some attachments.



Specifications

Model		SVL65-2		
Type of operator station		Open CAB / Closed CAB		
Engine	Model	V2607-CR-TE4		
	Output (SAE J1995 gross)	HP (kW)/rpm	68.3 (51.0) / 2600	
	Output (SAE J1349 net)	HP (kW)/rpm	60 (44.7) / 2600	
	Displacement	cu.in. (cc)	159.6 (2615)	
	Cylinders		4	
	Bore × Stroke	in. (mm)	3.4 (87) × 4.3 (110)	
Loader Performance	Aspiration	Turbocharged		
	Rated operating capacity-35% tipping load	lbs. (kg)	2100 (953)	
	Tipping load	lbs. (kg)	6000 (2722)	
	Breakout force	Bucket	lbf. (kg)	4614 (2093)
		Lift arm	lbf. (kg)	4266 (1935)
Lift arm path	Vertical			
Undercarriage	Track Width	Standard	in. (mm)	12.6 (320)
		Wide	in. (mm)	15.0 (380)
	Ground pressure	Standard	psi	5.0
		Wide	psi	4.2
	Track rollers (per side)			4
	Track ground contact length	in. (mm)		57.9 (1470)
	Travel speed	Low	mph (km/h)	4.9 (7.8)
		High	mph (km/h)	7.1 (11.5)
Traction force	lbf. (kgf)		8406 (3813)	
Min. ground clearance	in. (mm)		9.1 (233)	
Hydraulic system	Aux. hydraulic flow	Std./High Flow	gpm (ℓ/min.)	17.4 (65.8) / 27.0 (102.2)
	Aux. hydraulic pressure	psi (kgf/cm ²)		3263 (229.4)
Service refill capacities	Hydraulic system	gal. (ℓ)		13.2 (50)
	Hydraulic tank	gal. (ℓ)		5.4 (20.3)
	Fuel tank	gal. (ℓ)		21.7 (82)
Operating weight (Includes operator weight 165lbs.)		lbs. (kg)		8035 (3645) / 8465 (3840)

The company reserves the right to change the above specifications without notice. This brochure is for descriptive purposes only. Please contact your local Kubota dealer

Dimensions

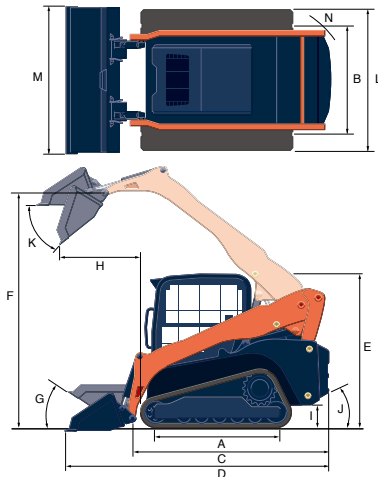

Model		SVL65-2	
A	Length of track on ground	in. (mm)	57.9 (1470)
B	Track gauge	in. (mm)	52.6 (1337)
C	Length w/o bucket	in. (mm)	107.3 (2725)
D	Length w/bucket on ground	in. (mm)	136.4 (3465)
E	Height to top of cab	in. (mm)	79.9 (2029)
F	Bucket hinge pin height at max. lift	in. (mm)	118.5 (3010)
G	Rollback angle at carry position	degree	30
H	Reach at max. lift and dump	in. (mm)	34.9 (886)
I	Ground clearance	in. (mm)	9.1 (233)
J	Departure angle	degree	30
K	Max. dump angle	degree	40
L	Vehicle width Standard track / Wide track	in. (mm)	65.2 (1657) / 67.6 (1717)
M	Width with bucket	in. (mm)	68 (1727) / 74 (1880)
N	Turning radius from center-machine rear	in. (mm)	57.1 (1451)

Kubota Tractor Corporation reserves the right to change the stated specifications without notice. This brochure is for descriptive purposes only and reasonable efforts were used to set forth the contained information; some items shown may be optional and some products shown may not be available at all dealerships. Kubota disclaims all representations and warranties, express or implied, or any liability from the use of this brochure. For complete warranty, safety and product information, consult your local Kubota dealer and the operator's manual. Power (HP/KW) and other specifications are based on various standards or recommended practices. For your safety, Kubota strongly recommends the use of a Rollover Protective Structure (ROPS) and seat belt in almost all applications. This brochure is intended for the United States and US territories only. For information regarding Kubota products or services outside these areas, see Kubota Corporation's global web site. Kubota does not provide parts, warranty or service for any Product which is re-sold or retailed in any country other than the country for which the Product(s) were designed or manufactured.



KUBOTA TRACTOR CORPORATION

1000 Kubota Drive, Grapevine, TX 76051 Tel 888-4 KUBOTA

Visit our web site at: www.kubotausa.com

©2018 Kubota Corporation



Kubota Genuine Parts
for maximum performance, durability and safety